

Entrance Examination for Engineering Education

Universities of Applied Sciences

29.4.2009

INSTRUCTIONS

The examination consists of two parts:

Part 1: Mathematics, Logical deduction, Physics and Chemistry.

Part 2: English language.

The test in Mathematics, Logical deduction, Physics and Chemistry

The duration time is 2 hours and 30 minutes.

You may not leave the examination room within the first 30 minutes.

You may only bring your writing material (pencil, sharpener, rubber and ruler) and your calculator to the examination. Formula books and dictionaries are not allowed.

Answer sheets and extra paper are distributed with the exam papers.

There are 10 problems to be solved; each worth 3 points. Write your solutions on the provided answer sheets.

Include calculation details whenever the solution requires calculations.

For problems 8, 9 and 10, you have to choose either A (Physics) or B (Chemistry). If you solve both, the one with the lower score will count.

Only solutions written on your answer sheets will be checked!

All papers must be returned.

Your mobile phone must be switched OFF!

Mathematics, Logical deduction, Physics and Chemistry

1. Solve the following equations, an exact answer is required.

a) $6x = 3 - 2(3 + x)$

b) $5 = \frac{x+2}{3} - \frac{x-3}{2}$

2. A right triangle ABCD is formed from 4 jointed links. The midpoint D of the hypotenuse is moved on the leg AB. Find the height x , when $a = 50\text{mm}$.

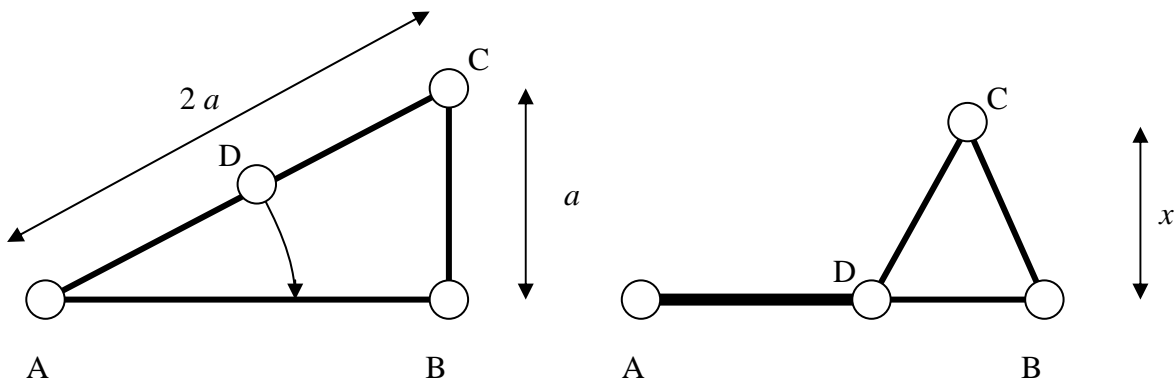

3. Simplify

a) $\frac{\frac{1}{x} - x}{\frac{1}{x} + 1}$

b) $x^2 + 1 - (x-1)^2$

4. What is the height of the tree?

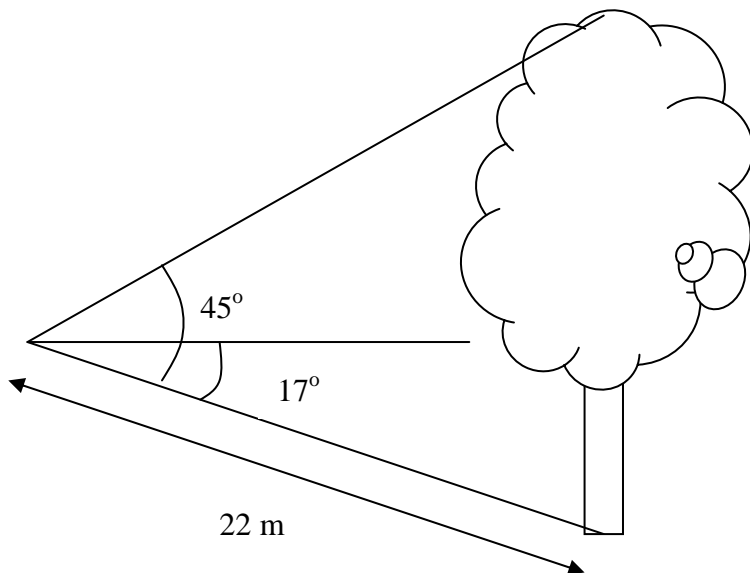

5. Please draw the following building as seen from the north. Pay attention to details like the height of the flag pole.

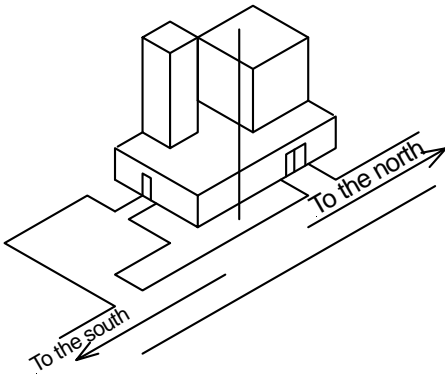

- A. How many metres high is the highest part of the building if the height of each floor is 3 metres 60 centimetres?
- B. Estimate the height of the flag pole!

6. You are a pyramid construction manager in ancient Egypt. One of your tasks is to move stone blocks from stone works to the pyramids 24 kilometres away.

You hit upon the bright idea of rolling the blocks on large wooden rollers. Each of your rollers has a circumference of 250 centimetres. You are placing the wooden rollers every 125 centimetres under the stone. You are using only six wooden rollers.

Assume there is no incidental sliding motion. How many times do your working men need to place a wooden roller left behind again in front of the great stone block?

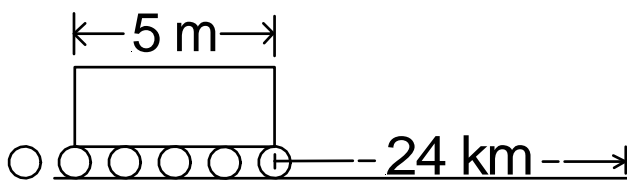

Solve either problem 9.A or 9.B, not both. If you solve both, the one with the lower score will be chosen as your answer.

9.A Three identical blocks, each of mass 0,6 kg, are connected by light strings. Assume that they lie on a frictionless, horizontal surface and are observed to have an acceleration of $4,0 \text{ m/s}^2$ under the action of a force F . Calculate F and two tension forces T_{bc} and T_{ab} .



9.B Dinitrogen monoxide (nitrous oxide) N_2O decomposes producing nitrogen and oxygen gases. Calculate the total volume of produced gases at STP, when 8.8 grams of dinitrogen monoxide decomposes?

The atomic masses are N: 14.0 and O: 16.0

The molar volume of an ideal gas at STP is $22.4 \text{ dm}^3/\text{mol}$

Solve either problem 10.A or 10.B, not both. If you solve both, the one with the lower score will be chosen as your answer.

10.A A man runs at a speed of $4,0 \text{ m/s}$ to overtake a standing bus. When he is $6,0 \text{ m}$ behind the door, the bus moves forward and continues with a constant acceleration of $1,2 \text{ m/s}^2$.

- How long does it take for the man to reach the door ?
- If in the beginning he is $10,0 \text{ m}$ from the door, will he (running at the same speed) ever catch up ?

10.B The following hydrocarbons have different structures but the same atoms except for one. Which of them is this exception and what is the difference?

- cyclobutane
- 1-butene
- 2-butene
- cyclobutene
- methylcyclopropane